

HYDAC INTERNATIONAL

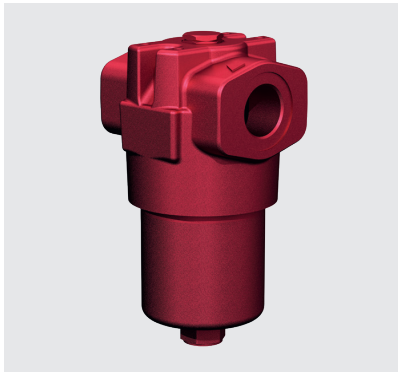

MDF Pressure filter

Symbol for hydraulic systems:

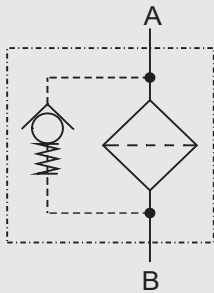

1. SIZES

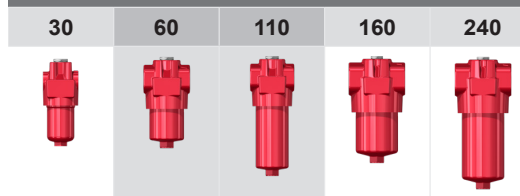

2. TECHNICAL DATA

Filter specifications

| | |
|-------------------------|---|
| Nominal pressure | 280 bar |
| Maximum flow rate | 280 l/min |
| Temperature range | -30 °C to + 100 °C (-30 °C to -10°C: max. 140 bar) |
| Material of filter head | EN-GJS-400-15 |
| Material of filter bowl | Steel |

Clogging indicator

| | |
|------------------|---------|
| Type | VD |
| Pressure setting | 5.0 bar |

Bypass (optional)

| | |
|-------------------|---------|
| Cracking pressure | 6.0 bar |
|-------------------|---------|

Miscellaneous

| | |
|--------------------------------|---|
| Seal | NBR (= Perbunan) |
| Mounting | As inline filter |
| Special models and accessories | <ul style="list-style-type: none"> • Bypass valve built into the head, separate from the main flow • Oil drain plug • Seals in FKM • Test and approval certificates |
| Spare parts | See spare parts list. |
| Certificates and approvals | <ul style="list-style-type: none"> • Test certificate 2.2 • Manufacturer's certificate O and M to DIN 55350, part 18 • Others on request |

3. GENERAL DESCRIPTION

3.1 FILTER HOUSING

Design

The filter housings are designed in accordance with international regulations. They consist of a filter head and a screw-in filter bowl.

Standard model

- without bypass valve
- connection for a clogging indicator in filter head
- mounting holes in the filter head

3.2 FILTER ELEMENTS

HYDAC filter elements are validated and their quality is constantly monitored according to the following standards: ISO 2941, ISO 2942, ISO 2943, ISO 3724, ISO 3968, ISO 11170, ISO 16889.

Filter elements are available with the following collapse pressure stability values:

| Designation | Model code | Collapse pressure |
|-------------|------------|-------------------|
| Optimicron® | ON | 20 bar |
| Betamicron® | BH4HC | 210 bar |
| Wire mesh | W | 20 bar |

3.3 FATIGUE STRENGTH

Design

The fatigue strength is at least 5 million cycles at 1.2 times the nominal pressure.

Other pressures can be obtained from the diagram:

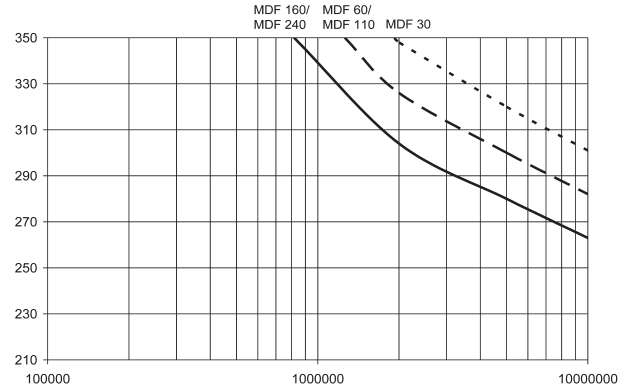

3.4 COMPATIBILITY WITH HYDRAULIC FLUIDS (ISO 2943)

- Hydraulic oils HL to HVL (DIN 51524)
- Lubrication oils (DIN 51517, API, ACEA, DIN 51515, ISO 6743)
- Compressor oils (DIN 51506)
- Biodegradable operating fluids: HETG, HEES, HEPG (VDMA 24568)
- Fire-resistant fluids HFA, HFB, HFC, HFD (ISO 12922)
- Operating fluids with a high water content (>50% water content) on request

3.5 IMPORTANT INFORMATION

- The filter housings must be earthed e.g. via the system/pipe.
- When using electrical clogging indicators, the electrical power supply to the system must be switched off before removing the clogging indicator connector.

4. MODEL CODE

4.1 FILTER ASSEMBLY

MDF ON 60 O C 10 D 1 . X /-L24

Filter type

MDF

Filter material

ON Optimicron®
 BH/HC Betamicron®
 W stainless steel wire mesh

Size of filter or element

30, 60, 110, 160, 240

Operating pressure

O 280 bar

Type and size of connection

| Type | Connection | Filter size | | | | |
|------|------------|-------------|----|-----|-----|-----|
| | | 30 | 60 | 110 | 160 | 240 |
| B | G½ | • | | | | |
| C | G¾ | | • | • | | |
| E | G1¼ | | | | • | • |

Filtration rating in µm

ON 3, 5, 10, 20
 BH/HC 3, 5, 10, 20
 W 25, 50, 100, 200

Type of clogging indicator

A with steel blanking plug in indicator port
 B visual
 C electrical
 D visual and electrical

Type code

1

Modification number

X the latest version is always supplied

Supplementary details

B. bypass cracking pressure (e.g. B6 = 6 bar); without details = without bypass valve
 L... lamp with appropriate voltage (24V, 48V, 110V, 220V)
 V FKM seals

4.2 REPLACEMENT ELEMENT

0060 D 010 ON /-V

Size

0030, 0060, 0110, 0160, 0240

Type

D

Filtration rating in µm

ON 003, 005, 010, 020
 BH4HC 003, 005, 010, 020
 W 025, 050, 100, 200

Filter material

ON, BH4HC, W

Supplementary details

V FKM seal

4.3 CLOGGING INDICATOR

VD 5 D . X /-L24

Type

VD differential pressure indicator up to 420 bar operating pressure

Pressure setting

5 standard 5 bar

Type of clogging indicator

D see point 4.1

Modification number

X the latest version is always supplied

Supplementary details

L... lamp with appropriate voltage (24V, 48V, 110V, 220V)
 V FKM seals

EN 7.502.5/12.19

5. FILTER CALCULATION

The total pressure drop of a filter at a particular **flow rate Q** and **viscosity ν** consists of the sum of the **housing pressure drop $\Delta p_{\text{housing}}$** and the **element differential pressure $\Delta p_{\text{element}}$** and can be calculated as follows:

$$\Delta p_{\text{total}} = \Delta p_{\text{housing}} + \Delta p_{\text{element}}$$

$\Delta p_{\text{housing}}$ [bar] = see housing curves

$$\Delta p_{\text{element}}$$
 [bar] = Q [l/min] $\cdot \frac{SK [\text{mbar} / (\text{l/min})]}{1000} \cdot \frac{\nu [\text{mm}^2/\text{s}]}{30}$

SK = gradient coefficient (see point 5.2)

For ease of calculation, our Filter Sizing Program is available free of charge at:

www.hydac.com/de-en/service/online-tools

5.1 HOUSING CURVES

The housing curves are based on ISO 3968. The housing curves apply to mineral oil with a density of 0.86 kg/dm³ and a kinematic viscosity of 30 mm²/s. In this case, the differential pressure changes proportionally to the density.

MDF 30

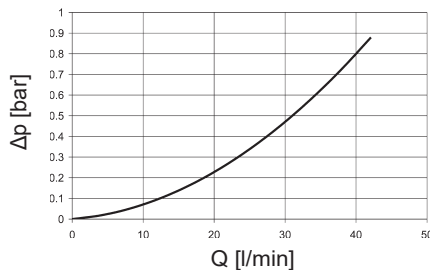

MDF 60-110

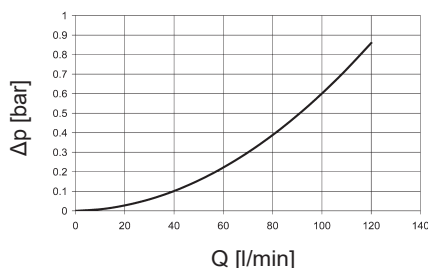

MDF 160-240

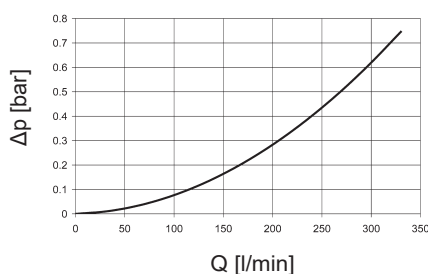

5.2 GRADIENT COEFFICIENTS (SK)

The gradient coefficients in mbar/(l/min) apply to mineral oils with a kinematic viscosity of 30 mm²/s. The pressure drop changes proportionally to the change in viscosity.

| Size | ON | | | | W |
|------|-------|-------|-------|-------|-------|
| | 3 μm | 5 μm | 10 μm | 20 μm | |
| 30 | 63.90 | 43.60 | 22.80 | 11.30 | 3.030 |
| 60 | 26.00 | 18.30 | 12.10 | 6.32 | 0.757 |
| 110 | 13.40 | 9.61 | 6.06 | 2.99 | 0.413 |
| 160 | 11.00 | 7.70 | 4.10 | 3.18 | 0.284 |
| 240 | 6.90 | 5.34 | 3.19 | 2.10 | 0.189 |

| Size | BH4HC | | | |
|------|-------|------|-------|-------|
| | 3 μm | 5 μm | 10 μm | 20 μm |
| 30 | 91.2 | 50.7 | 36.3 | 19.0 |
| 60 | 58.6 | 32.6 | 18.1 | 12.2 |
| 110 | 25.4 | 14.9 | 8.9 | 5.6 |
| 160 | 16.8 | 10.4 | 5.9 | 4.4 |
| 240 | 10.6 | 6.8 | 3.9 | 2.9 |

5.3 MAXIMUM FLOW RATE

The following maximum permitted flow rates (Q_{max}) in l/min are possible for the various sizes and connection sizes:

| Size | Connection | Q_{max} |
|------|------------|------------------|
| | | [l/min] |
| 30 | B | 30 |
| 60 | C | 80 |
| 110 | C | 110 |
| 160 | E | 260 |
| 240 | E | 280 |

Information regarding calculation:

The hydraulic load on the filter element is primarily determined by the flow rate and the geometry of the particular filter element. Exceeding the maximum permitted flow rate (Q_{max}) and therefore the permitted hydraulic load can destroy the filter element.

Even the choice of operating medium can influence system performance and lead to problems during use such as electrostatic discharges.

Adherence to the maximum permitted flow rate should always be ensured throughout the system project planning process.

If you have any questions regarding calculation or project planning, please contact the technical sales department at HYDAC Filtrertechnik.

6. DIMENSIONS

NOTICE:

The MDF filter dimensions for **version 1.3** are slightly different to those for version 1.0.

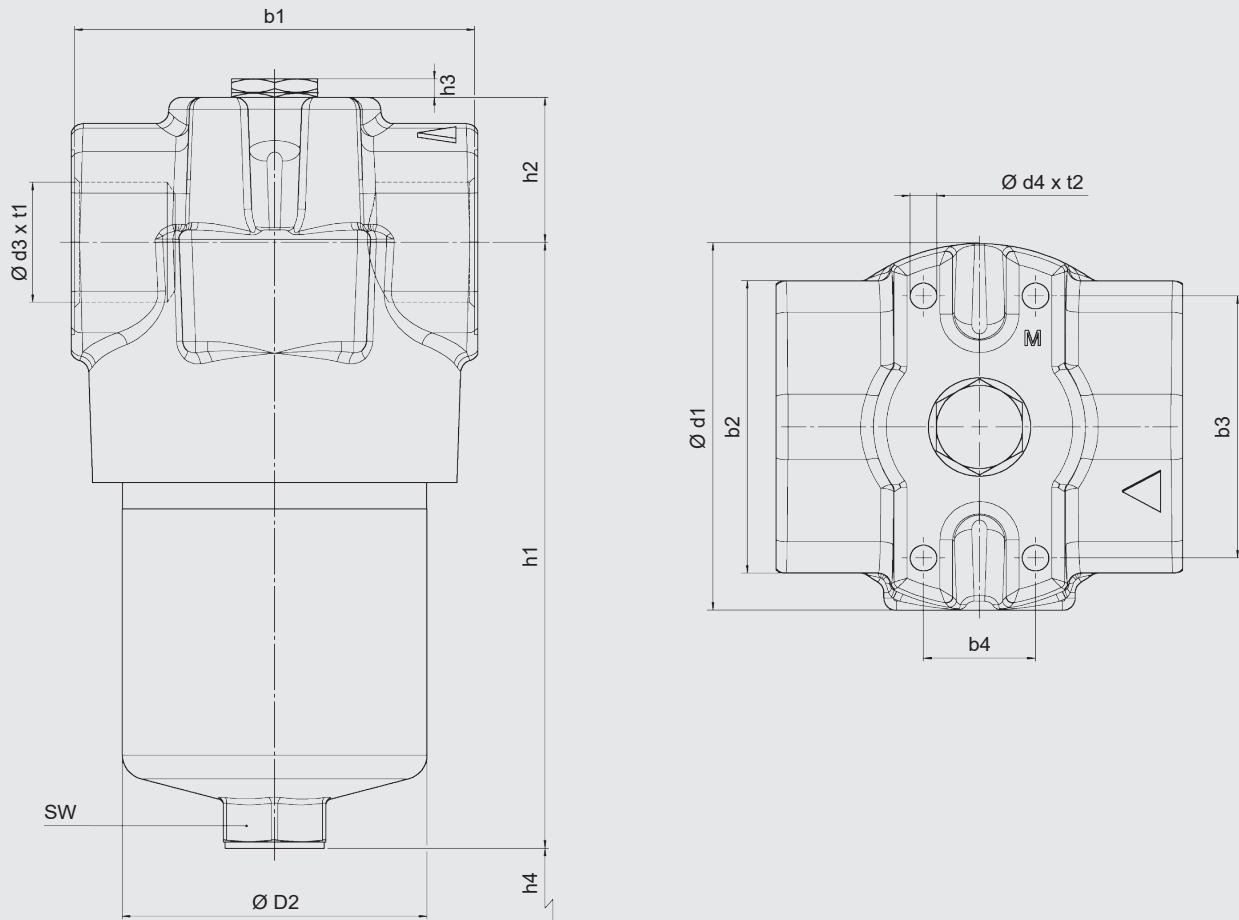

| Size | b1 | b2 | b3 | b4 | d1 | d2 | d3 | d4 | h1 | h2 | h3 | h4 | AF width | t1 | t2 | Weight incl. element [kg] | Volume of pressure chamber [l] |
|------|-----|----|----|----|-----|----|------|-----|-------|----|----|-----|----------|----|----|---------------------------|--------------------------------|
| 30 | 68 | 38 | 45 | 30 | 69 | 52 | G ½ | M5 | 130.5 | 38 | 6 | 75 | 24 | 14 | 6 | 2.3 | 0.13 |
| 60 | 90 | 71 | 56 | 32 | 86 | 68 | G ¾ | M6 | 144 | 40 | 6 | 85 | 27 | 16 | 9 | 4.5 | 0.20 |
| 110 | 90 | 71 | 56 | 32 | 86 | 68 | G ¾ | M6 | 213.5 | 40 | 6 | 85 | 27 | 16 | 9 | 5.4 | 0.33 |
| 160 | 125 | 95 | 85 | 35 | 119 | 95 | G 1¼ | M10 | 197 | 47 | 6 | 105 | 32 | 20 | 14 | 10.2 | 0.60 |
| 240 | 125 | 95 | 85 | 35 | 119 | 95 | G 1¼ | M10 | 256 | 47 | 6 | 105 | 32 | 20 | 14 | 11.7 | 0.80 |

NOTE

The information in this brochure relates to the operating conditions and applications described.

For applications and/or operating conditions not described, please contact the relevant technical department.

Subject to technical modifications.

HYDAC Filtrertechnik GmbH
 Industriegebiet
D-66280 Sulzbach/Saar
 Tel.: 0 68 97 / 509-01
 Fax: 0 68 97 / 509-300
 Internet: www.hydac.com
 E-mail: filter@hydac.com

EN 7.502.5/12.19

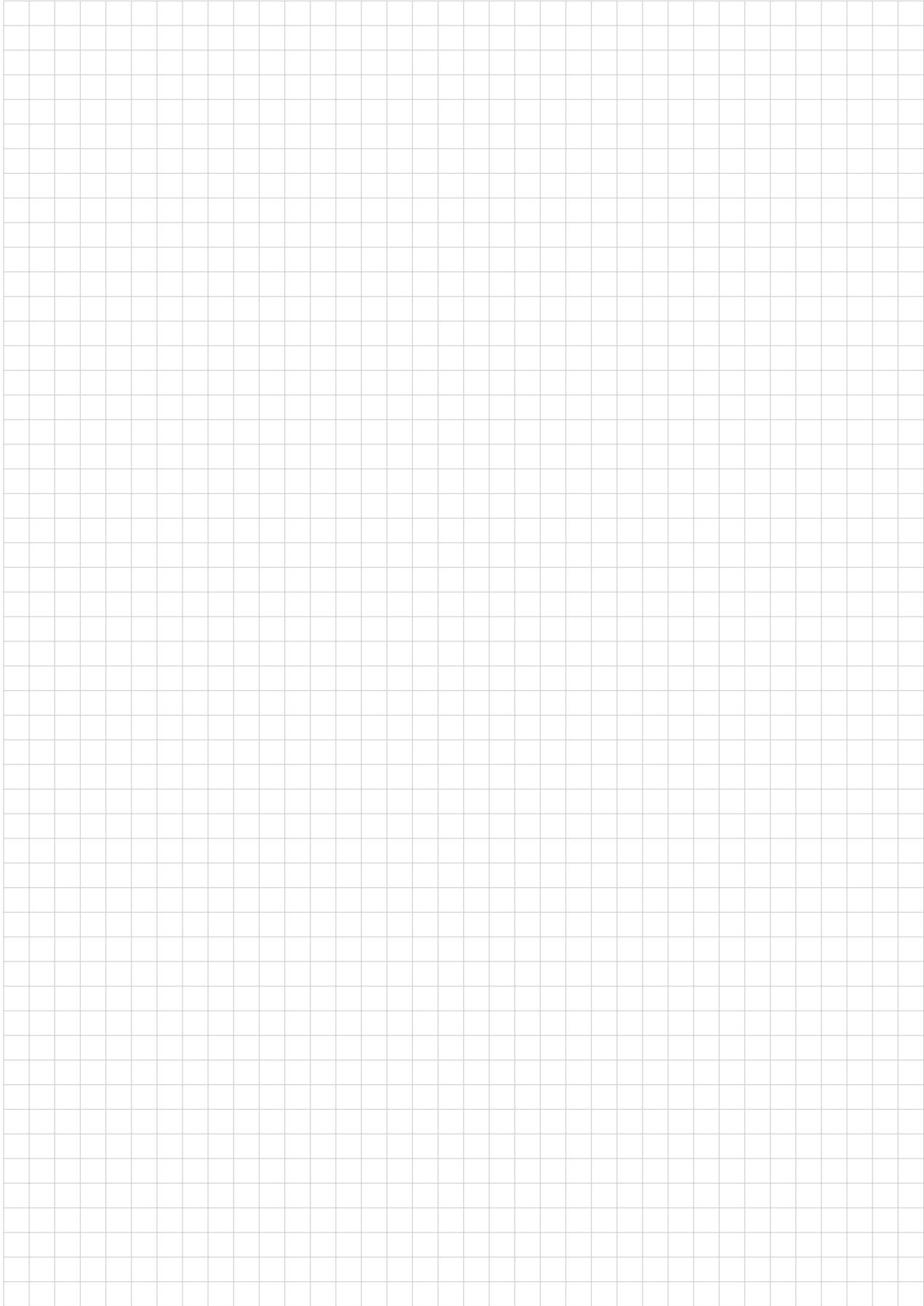

EN 7.502.5/12.19